

Breather caps

with double valve and bayonet assembly, steel

MATERIAL

- Cover: steel sheet, with chrome plating superficial treatment.
- Flange: zinc-plated steel sheet.
- Bayonet and flange with bayonet: zinc-plated steel sheet.

PACKING RINGS

Three flat packing rings in NBR synthetic rubber.

OVERPRESSURE VALVE (ONLY FOR SMW-BA)

Technopolymer with NBR synthetic rubber O-ring and stainless steel spring.

Set at around 0.350 bar (0.700 bar on request).

SUCTION VALVE (ONLY FOR SMW-BA)

Technopolymer sealing disk with NBR synthetic rubber O-ring and stainless steel spring.

Set at around 0.030 bar.

RING-SHAPED AIR FILTER

Tech-foam 40 μ.

FILTER SETTING SPRING (ONLY FOR SMN-BA)

Zinc-plated steel.

FILTRATION BASKET

Electro zinc-plated steel, degree of filtration 800 μ.

SAFETY CHAIN (ONLY FOR SMN.80-BA/SMW.80-BA)

Brass

STANDARD EXECUTIONS

- **SMN-BA**: breather cap.
- **SMW-BA**: double-valve breather cap.

MAXIMUM CONTINUOUS WORKING TEMPERATURE

100°C.

SPECIAL EXECUTIONS ON REQUEST

With dipstick for fluid level indication (only for SMW-BA).



MOUNTING

- SMN.46: by means of three glossy zinc-plated steel screws with screwdriver slot head M5x12, supplied.
- SMN.80 SMW.80: by means of six glossy zinc-plated steel screws with screwdriver slot head M5x12, supplied.

Drilling templates

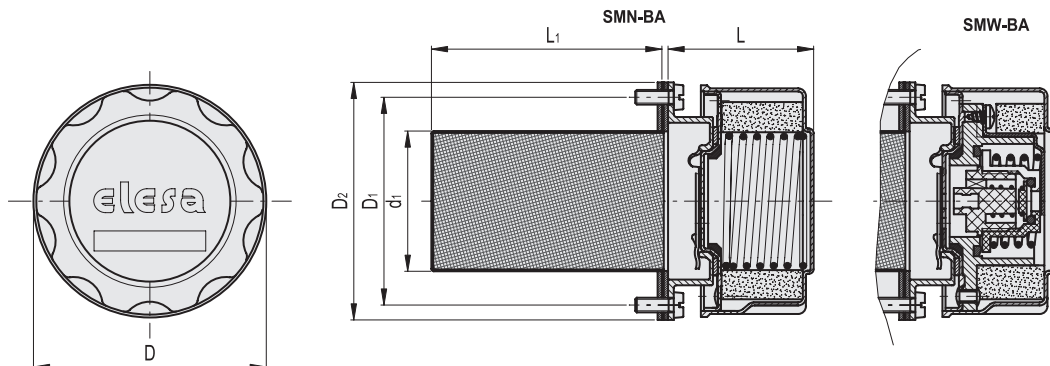
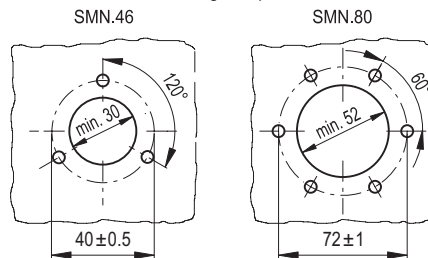

SMN-BA

Code	Description	D	D1	D2	L	L1	d1	△
156836	SMN.46-BA-F40	47	40	52	42	66	27	113
156886	SMN.80-BA-F40	81	72	83	55	80	49	375

SMW-BA

Code	Description	D	D1	D2	L	L1	d1	△
156986	SMW.80-BA-F40-350mb	81	72	83	55	80	49	445

FEATURES AND APPLICATIONS

Double-valve breather caps SMW.BA with bayonet assembly creates a pressure plenum chamber right above the oil level within given limit conditions in order to avoid any reservoir deformation.

Advantages:

- it reduces reservoir air volume intake keeping clean fluid and filter;
- it improves suction pump action under working conditions reducing cavitation phenomenon;
- it prevents fluid leakage when the system is part of a mobile unit;
- it reduces foam in fluid.

TECHNICAL DATA

Air flow rate for the different executions of breather caps can be obtained from the diagram on the basis of the difference of air pressure inside and outside the reservoir. Tests carried out without filtration basket.

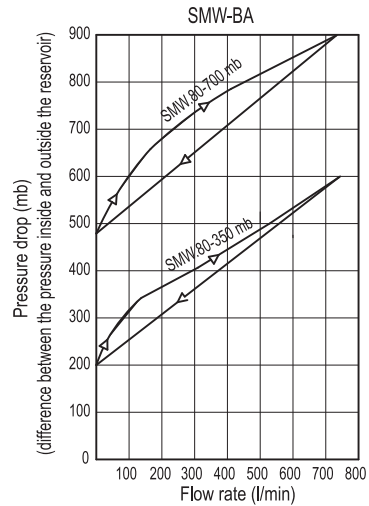
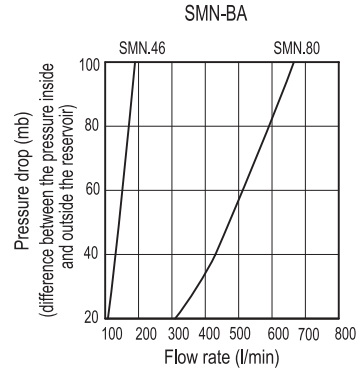

SMW-BA pressurised breather cap functioning in a hydraulic circuit

